

CODING ENHANCED JOINT DETECTION FOR MULTIPLE ACCESS COMMUNICATIONS

Rachel Learned, Andrew C. Singer

Sanders, A Lockheed Martin Company
Nashua, NH, 03161-0868

ABSTRACT

A low complexity approach to coding-enhanced multi-user detection is developed to mitigate the problems associated with near-far effect and to permit a more efficient assignment of channel resources relative to current multiple access (MA) communications systems. Through prudent integration of error correction decoding, multi-user and inter-symbol interference equalization and stripping, a low complexity near-far resistant multi-user joint detector/decoder has been developed which exhibits significant performance gains relative to the best known low complexity joint detection/decoding procedures reported in recent literature. Empirical analysis of the coding-enhanced multi-user detector (CMD) for a case of heavy inter-symbol interference and multi-user interference shows a 3 dB improvement over these best known methods.

1. BACKGROUND

Optimal multi-user joint detection eliminates the problem of multi-user interference (MUI) which, left uncontrolled, would render MA communications systems of today inoperable. To lessen MUI in current systems, transmissions from different users are constructed to exhibit as little interference as possible. Specifically, user transmissions are designed to be nearly orthogonal leading to an inefficient allocation of channel resources. Forcing user transmissions to be nearly orthogonal, even at the expense of inserting wasteful buffer zones in which no user is permitted to transmit, is common practice in present systems.

Creating near orthogonality among users, however, does not solve the joint detection problem entirely. The near-far problem, in which nearly-orthogonal users are of greatly differing receive powers, prohibits the conventional detector from detecting the low power users [1]. This near-far effect is handled in present systems with the use of power control requiring continuous monitoring by the base station and a set aside of valuable channel resources for the control signal. Current methods of dealing with interference and the near-far problem strictly limits the number of users that can be fit into the total available bandwidth allotted to a system.

Beginning with the development of the decorrelating detector of Lupas and Verdu in 1989 [2], many researchers have shown that a significant resistance to MUI and the near-far problem can be obtained with the joint detection of all users in an MA system. Moreover, allowing for high interference will allow for a close

This work was prepared through participation in the Advanced Telecommunications/Information Distribution Research Program (ATIRP) Consortium sponsored by the U.S. Army Research Laboratory under the Federated Laboratory Program, Cooperative Agreement DAAL01-96-2-0002.

packing of users within the available bandwidth which will lead to significant gains in MA throughput.

The majority of the literature in the area of MA joint detection has focussed on uncoded transmission. For most wireless scenarios, however, uncoded transmission will not give the needed bit error rates (even in the single user case), hence, error correction coding must be used. This paper develops a joint detection procedure that takes advantage of the error correction coding that is inherent to MA transmissions.

A maximum likelihood approach to joint detection and decoding presented by Giallorenzi and Wilson in [3] will eliminate the need for wasteful user allocation and nearly eliminate the need for power control. The drawback to the ML joint detector/decoder is its crippling complexity. A more practical approach is to use one of the many low complexity suboptimal joint detectors [2, 4, 5] followed by a decoder. While this concatenated approach has low complexity, it does not offer the gains needed for typical systems operating in a moderate interference environment.

An alternative and potentially more promising approach is the integration of error correction decoding and low complexity joint detection. This integrated approach was first addressed by Giallorenzi and Wilson in [6]. The Giallorenzi and Wilson algorithm (GW), being the best known low complexity method up to now, is used as a basis for comparison in this paper.

We continue the exploration of integrating detection and decoding by showing that a prudent combination of error correction decoding and low complexity joint detection can out-perform both the concatenation approach and the Giallorenzi and Wilson integrated approach. The coding-enhanced multi-user detector (CMD) developed in this paper was designed to accommodate moderate to high MUI and high near-far ratios. The concatenated and GW methods begin to break down under moderate MUI with high near-far ratios. Furthermore, under high MUI, these cannot support reliable communication for the lower power users, causing a drop-out of the weakest users in an MA system. As is expected from close examination of the CMD algorithm and as was found via simulation, the CMD appears insensitive to increasing near-far ratios, preventing drop-out of low power users in MA systems of highly interfering users.

2. PROBLEM STATEMENT

Consider a multiple access communication system with K users, where each user has been assigned a signature waveform of duration T . The received waveform due to the transmission of a single pulse from user i is denoted by $s_i(t)$. For example, in a direct sequence spread spectrum system the noise-free received waveform

corresponding to the transmission of user i would be

$$s_i(t) = \cos(w_c t) \sum_{j=1}^M g\left(t - j\frac{T}{M}\right) c_i[j],$$

where $g(t)$ is the chip pulse, w_i is the carrier frequency, $\{c_i[j]\}_{j=1}^M$ is the chip sequence for user i , and M is the number of chips in the spreading sequence.

Each user transmits successive pulses modulated by one of a finite set of amplitudes or information weights, $b_i[p]$, where p is an integer denoting the time frame. The noise-free reception from a single user over a duration of P time frames is

$$\sum_{p=1}^P b_i[p] s_i(t - (p-1)T).$$

For example, the weights, $b_i[p]$, $p = 1, \dots, P$, could be unit magnitude complex scalars, corresponding to phase shift keying (PSK), or any arbitrary amplitude shift keying (ASK) system such as binary phase shift keying (BPSK) in which $b_i[p] \in \{\pm 1\}$.

Depending on the transmitter and the channel, the received signature waveform, $s_i(t)$, may be of duration longer than T . Time spreading channels are a common cause of inter-symbol interference (ISI) at the receiver. Another source of ISI is the deliberate time overlapping of transmitted pulses that is done when the non-zero portion of a signature pulse is longer than the desired transmission rate.

The inter-symbol interference level is defined as a normalized inner product between received pulses from the same user, but at different time frames,

$$\rho_{i,i}[p] = \frac{\langle s_i(t), s_i(t - pT) \rangle}{\|s_i(t)\|^2},$$

and is assumed to be non-negligible for the derivation of the detector/decoder in this paper.

The multiple access received signal over a finite duration, PT , is denoted by $r(t)$

$$r(t) = \sum_{i=1}^K \sum_{p=1}^P b_i[p] s_i(t - (p-1)T) + \sigma n(t), \quad (1)$$

where $\sigma n(t)$ denotes the noise process seen by the receiver. By using the notion of signal space we may write the received signal in terms of a received signal vector

$$\mathbf{r} = \sum_{i=1}^K \sum_{p=1}^P b_i[p] \mathbf{s}_i[p] + \sigma \mathbf{n}, \quad (2)$$

where $\mathbf{s}_i[p]$ is a vector of N coefficients representing the received waveform at time frame p corresponding to a pulse transmitted by user i . For example, the N coefficients could be the output of N orthogonal receiver correlation filters $\{h_i(t)\}_0^N$ which span the same space as spanned by $\{s_i(t - pT)\}_{i=1,2,\dots,K, p=1,\dots,P}$. Further shorthand is obtained by writing

$$\mathbf{b}_i = [b_i[1] \ b_i[2] \ \dots \ b_i[P]]^T, \quad (3)$$

$\mathbf{b} = [\mathbf{b}_1^T \ \mathbf{b}_2^T \ \dots \ \mathbf{b}_K^T]^T$, and $\mathbf{S} = [s_1[1] \ s_1[2] \ \dots \ s_1[P] \ s_2[1] \ \dots \ s_2[P] \ s_K[1] \ \dots \ s_K[P]]$ so that we may re-write Equation (2) as

$$\mathbf{r} = \mathbf{S}\mathbf{b} + \sigma \mathbf{n}. \quad (4)$$

The noise vector, \mathbf{n} , for this paper, is assumed to be Gaussian with zero mean and identity covariance. This is a good approximation for some MA systems such as satellite systems.

For current time-division, frequency division, and direct sequence spread spectrum systems, the signature waveforms are assigned so that \mathbf{S} is non-singular and can be written as square, i.e., $N = KP$. Moreover, for a system that has been designed for the signature waveforms to be nearly orthogonal, more user signatures can be added within the available signal space without disturbing the non-singularity of \mathbf{S} .

The cross correlation between user signatures, or MUI level between users i and j , will be denoted by

$$\rho_{i,j}[\tau] = \frac{\langle s_i(t), s_j(t - \tau T) \rangle}{\|s_i(t)\| \|s_j(t)\|} = \frac{\mathbf{s}_i[p]^T \mathbf{s}_j[p - \tau]}{\|\mathbf{s}_i\| \|\mathbf{s}_j\|},$$

where τ is an integer.

Either a block or convolutional coding method may be used with joint detection/decoding. For ease of presentation, development of the CMD assumes a rate (n, k) block code. In this case, the detection/decoding procedure is performed on one block of time. All users must transmit an n -bit weight sequence within a single time block allowing for the collection of a complete symbol from each user during a specified time frame. For such a scheme, $P = n$ in Equation (2) and the n -element sequence corresponding to the n -bit code word transmitted by user i in the symbol frame under examination at the receiver is $\mathbf{b}_i \in \{\pm 1\}^n$.

The problem at the receiver is to estimate \mathbf{b} given the user signature waveforms as seen by the receiver (\mathbf{S} is known at the receiver), the set from which \mathbf{b} was chosen (i.e. the user codebooks and the modulation scheme) and, possibly, σ . This must be achieved with a procedure of practical complexity.

3. THE CMD ALGORITHM

The CMD makes use of the different powers among user receptions and without loss of generality, we assume that the columns of \mathbf{S} are ordered from left to right from lowest power to highest power. Likewise, the weight vector \mathbf{b} is ordered to match the column order in \mathbf{S} . The CMD has two parts, the first is based on Q-R factorization and back substitution, and the second is based on MUI reconstruction. A block diagram of the CMD is shown in Figure 1. The four blocks of the algorithm are enumerated and detailed below.

Block 1 – MUI and ISI Equalization

Pass the incoming received signal through a linear equalization filter denoted by \mathbf{Q}^T , where \mathbf{Q} is a result of the Q-R factorization of the signature matrix \mathbf{S} , i.e.,

$$\mathbf{Q}\mathbf{R} = \mathbf{S}, \quad (5)$$

where, \mathbf{Q} is unitary and \mathbf{R} is upper triangular [7].

Block 2 – Decision feedback with error correction

Solve the linear equations

$$\mathbf{Q}^T \mathbf{r} = \mathbf{R}\mathbf{b} \quad (6)$$

with a modified back substitution. There are two differences, however, between the pure back substitution solution of Equation (6) and the CMD-block 2 procedure. First, each new element of \mathbf{b}

found by back substitution, beginning at the bottom of the weight vector, \mathbf{b} , and proceeding upward, element by element, is quantized prior to feeding it back. For example, in the BPSK case, the solution corresponding to each row of Equation (6) would be quantized to $\{\pm 1\}$. Second, only n adjacent elements of \mathbf{b} are estimated via *successive* back substitutions. The n adjacent elements correspond to the code word estimate of one of the users and can be corrected according to the known code book for this user. The corrected set of n adjacent elements in \mathbf{b} now corresponds to the nearest valid code word for that user. The recursion continues with n more elements of \mathbf{b} found via back substitution followed by error correction until all elements of \mathbf{b} have been estimated.

Note that since the columns of \mathbf{S} and the elements of \mathbf{b} have been arranged in ascending power order, this feedback procedure closely resembles power ordered stripping. The difference is that simple power ordered stripping ignores the presence of the MUI and ISI, while, for the CMD, the MUI and ISI have been "equalized" in block 1 prior to the stripping procedure. Duel-Hallen in [4] proposed using Q-R factorization decision feedback for the uncoded case of MA joint detection.

Block 3 – Code word refinement

Beginning with the lowest power user and working toward the highest, construct an estimate of the multi-user interference seen by this single user. Subtract this MUI and solve for this user's weight vector. Specifically, the MUI-adjusted received vector for user j is

$$\mathbf{r}_j = \mathbf{r} - \sum_{i \neq j} \sum_{p=1}^n \hat{b}_i[p] \mathbf{s}_i[p], \quad (7)$$

where the second term above is the reconstruction of the MUI as seen by user j . The reconstruction is made from the most recent estimates of the weights; either the most recent estimate of the weight $\hat{b}_i[p]$ was found in block 2, as described above, or has since been refined by this procedure which cycles through the users.

User j 's weight vector, \mathbf{b}_j , as defined in Equation (3), may be found in several ways. For relatively small codebooks a simple exhaustive search may be done.

$$\hat{\mathbf{b}}_j = \arg \min_{\mathbf{b}_j \in \Gamma} \|\mathbf{r}_j - \sum_{p=1}^n b_j[p] \mathbf{s}_j[p]\|, \quad (8)$$

where Γ is the set of all valid transmission sequences and is determined by the codebook for user j . Block 3 can then be iterated.

Block 4 – Decoding

The transmission weight sequences, $\hat{\mathbf{b}}_i$, for each user $i = 1, \dots, K$, are passed through the appropriate decoder to find the k information bits for each user.

4. EMPIRICAL ANALYSIS

Two simulations were run in which all users employ a Hamming (7,4) code. The first simulation was done with two users and the second was done with four. In both cases, all users experience ISI and MUI.

Figure 2 shows the result of a simulation of a two-user multiple access system. Successive bit transmissions of a single user exhibit ISI levels of $\rho_{i,i}[\pm 1] = 0.37$, $\rho_{i,i}[\pm 2] = 0.04$, $\rho_{i,i}[\pm p] = 0.0$, $|p| > 2$, $i = 1, 2$, and MUI levels of $\rho_{1,2}[0] = 0.38$, $\rho_{1,2}[\pm 1] =$

0.14 , $\rho_{1,2}[\pm 2] = 0.01$, $\rho_{1,2}[\pm p] = 0.0$, $|p| > 2$. In addition, there is a 10 dB separation in energy between the two users (one user has an energy 10 times that of the other).

Note that the CMD outperforms both the concatenated and the GW detector/decoder, both described in [6]. As shown in the figure, the CMD offers a 3 dB improvement in performance of the weaker user at a bit-error-rate (BER) of 0.004.

The improvement in performance can be explained by looking closer at the differences between the CMD and the concatenation and integrated procedures. The concatenation procedure comprises three parts: (1) find an estimate of each user's code word via simple stripping in timing order as opposed to power order, (2) perform two iterations of weight estimate refinement with MUI reconstruction for each user bit by bit, (3) end with error correction decoding [6]. The integrated detector/decoder comprises three parts: (1) find an estimate of each user's code word with a simple matched filter for each user as opposed to power ordered stripping and equalization of MUI and ISI, (2) correct each user's codeword, (3) refine the bit estimates with a bit by bit re-estimation using MUI-reconstruction, and repeat parts 2 and 3. All three detectors require knowledge of the user signature pulses and received powers in order to do their refinement steps. Only the CMD takes maximum advantage of this knowledge by performing MUI and ISI equalization to minimize the effect of interference, and power ordered stripping to achieve the lowest probability of error.

As would be expected, due to the high signal-to-noise ratio per information bit (E_b/N_o) for the stronger user, no errors were made by either detector/decoder, hence, no BER curves are shown for the higher power user.

A typical operating point for the weakest user of a satellite MA system might be $E_b/N_o = 4$ dB. From the figure, we see that, compared to the GW method, the CMD offers nearly an order of magnitude improvement in the coded BER of the weakest user, from a typically undesirable 5 in 100 errors down to approximately 0.8 in 100 errors.

Figure 3 shows the result of a simulation of an MA system of four interfering users which are received with energies differing by up to 10 dB. The differences relative to the highest energy user are 0 dB, -1.4 dB, -3.8 dB, -10 dB. Each user again employs a Hamming (7,4) error correction code. The ISI for this simulation is $\rho_{i,i}[\pm 1] = 0.37$, $\rho_{i,i}[\pm 2] = 0.04$, $i = 1, 2, 3, 4$, $\rho_{i,i}[\pm p] = 0.0$, $|p| > 2$, $i = 1, 2, 3, 4$. We assume that users were numbered such that the adjacent users interfere with one another while non-adjacent users are orthogonal. The non-zero MUI for this simulation is $\rho_{i,j}[0] = 0.38$, $\rho_{i,j}[\pm 1] = 0.14$, $\rho_{i,j}[\pm 2] = 0.01$, $|i - j| = 1$.

Figure 3 shows the bit error rate of the weakest user for concatenation detector/decoder, the GW integrated detector/decoder, and the CMD. The BER for an interference-free user is shown as a loose lower bound on BER. We again see a significant improvement in performance of the CMD for the lowest power user.

5. CONCLUSION

Through the integration of error correction decoding, multi-user and inter-symbol interference equalization and stripping, a low complexity near-far resistant multi-user joint detector/decoder has been developed to handle various levels of multi-user interference and inter-symbol interference. This coding-enhanced multi-user detector (CMD) exhibits a consistent and significant performance gain relative to the low complexity joint detection/decoding proce-

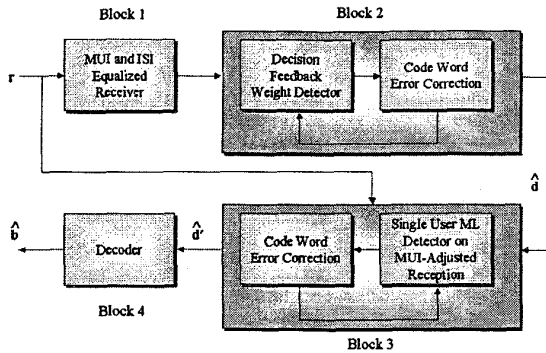

Figure 1: The coding-enhanced multi-user detector (CMD).

ture of Giallorenzi and Wilson in [6]. While both detectors require knowledge of the user signature pulses and received powers, only the CMD takes full advantage of this knowledge by performing MUI and ISI equalization to minimize the effect of interference, and power ordered stripping to achieve the lowest probability of error.

6. REFERENCES

- [1] S. Verdú, "Computational complexity of optimum multiuser detection," in *Algorithmica*, Springer-Verlag, 1989.
- [2] R. Lupas and S. Verdú, "Linear multiuser detectors for synchronous code-division multiple-access channels," *IEEE Trans. Inform. Theory*, vol. 35, Jan. 1989.
- [3] T. Giallorenzi and S. Wilson, "Multiuser ml sequence estimator for convolutionally coded asynchronous ds-cdma systems," *IEEE Trans. on Comm.*, vol. 44, pp. 997-1008, Aug. 1996.
- [4] A. Duel-Hallen, "Decision-feedback multiuser detector for synchronous code-division multiple access channel," *IEEE Trans. on Comm.*, vol. 41, Feb. 1993.
- [5] Z. Xie, C. K. Rushforth, and R. T. Short, "A family of suboptimum detectors for coherent multi-user communications," *Journal on Selected Areas of Communications*, pp. 683-690, May 1990.
- [6] T. Giallorenzi and S. Wilson, "Suboptimum multiuser receivers for convolutionally coded asynchronous ds-cdma systems," *IEEE Trans. on Comm.*, vol. 44, pp. 1183-96, Sep. 1996.
- [7] G. Strang, *Linear algebra and its applications*. Harcourt Brace Jovanovich, Inc., 1988.

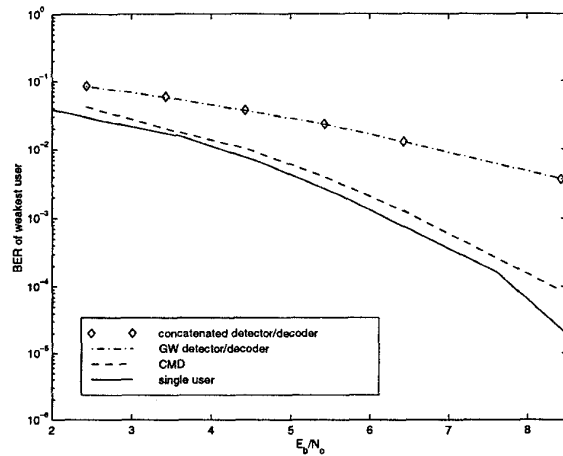

Figure 2: BER of the weakest user for the simulation of two interfering users which are received with a 10 dB energy difference employ a Hamming (7,4) error correction code. ISI: $\rho_{i,i}[\pm 1] = 0.37$, $\rho_{i,i}[\pm 2] = 0.04$, $i = 1, 2$. MUI: $\rho_{1,2}[0] = 0.38$, $\rho_{1,2}[\pm 1] = 0.14$, $\rho_{1,2}[\pm 2] = 0.01$.

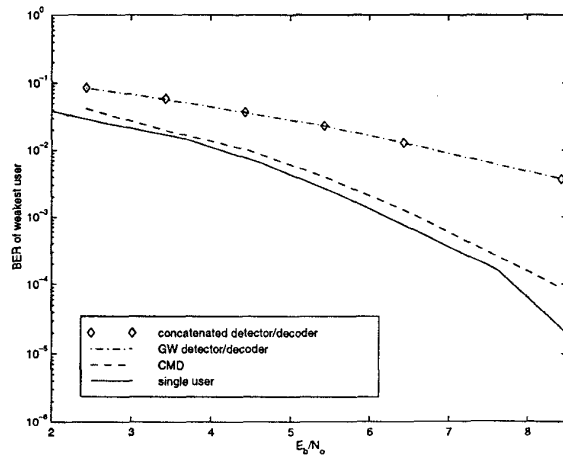

Figure 3: BER of the weakest user for the simulation of four interfering users which are received with the following energy differences relative to the highest energy user: 0 dB, -1.4 dB, -3.8 dB, -10 dB. Each user employs a Hamming (7,4) error correction code. ISI: $\rho_{i,i}[\pm 1] = 0.37$, $\rho_{i,i}[\pm 2] = 0.04$, $i = 1, 2, 3, 4$. MUI: $\rho_{i,j}[0] = 0.38$, $\rho_{i,j}[\pm 1] = 0.14$, $\rho_{i,j}[\pm 2] = 0.01$, $|i - j| = 1$.